

REINHOLD ENVIRONMENTAL Ltd.



**2013 Coal to Gas Conversion Round Table
& Expo Presentation**

October 29, 2013, in Chattanooga, TN / Sponsored by Southern Company

All presentations posted on this website are copyrighted by Reinhold Environmental, Ltd (RE). Any unauthorized downloading, attempts to modify or to incorporate into other presentations, link to other websites, or obtain copies for any other uses than the training of attendees to RE's Conferences is expressly prohibited, unless approved in writing by RE or the original presenter. RE does not assume any liability for the accuracy or contents of any materials contained in this library which were presented and/or created by persons who were not employees of RE.



thebabcock&wilcoxcompany

BMS and Combustion Control Considerations

***2013 Coal to Gas/PCUG Conference – Chattanooga TN
October 29, 2013***

John E. Bollinger
*Advisory Engineer
IC & E Engineering*

Key Topics

1. NFPA
2. Main Gas Supply
3. Igniter Gas Header
4. Main Gas Header
5. Venting
6. Flame Scanning
7. Combustion Control



National Fire Protection Association

Within the Boiler House – NFPA 85

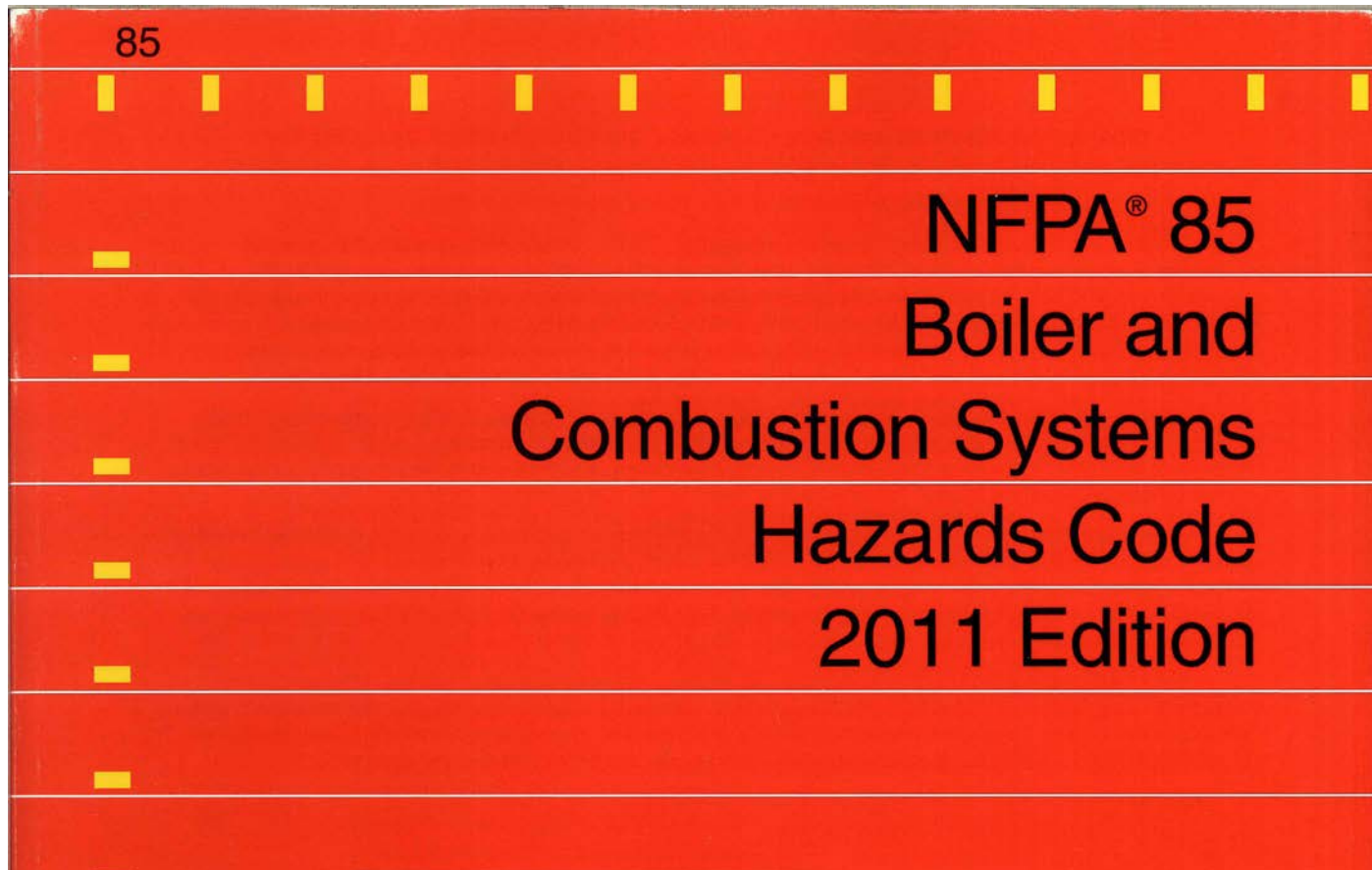

NFPA – Balance of Plant (External to the Boiler House)

1. Natural Gas Supply – NFPA 54 National Fuel Gas Code. External to the Boiler House.
2. Liquefied Natural Gas – NFPA 59A - Standard for the Production, Storage, and Handling of Liquefied Natural Gas. (LNG)

Potential use as a replacement for oil as an igniter fuel.

Main Gas Supply

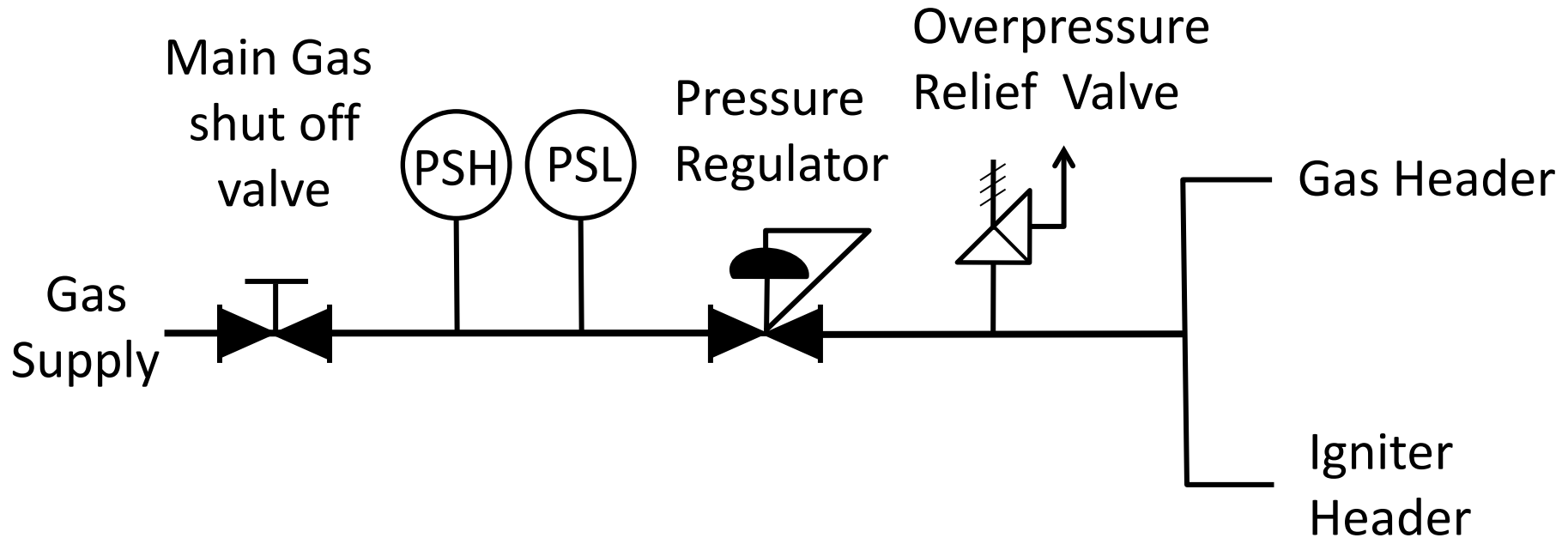

Igniter Gas Header

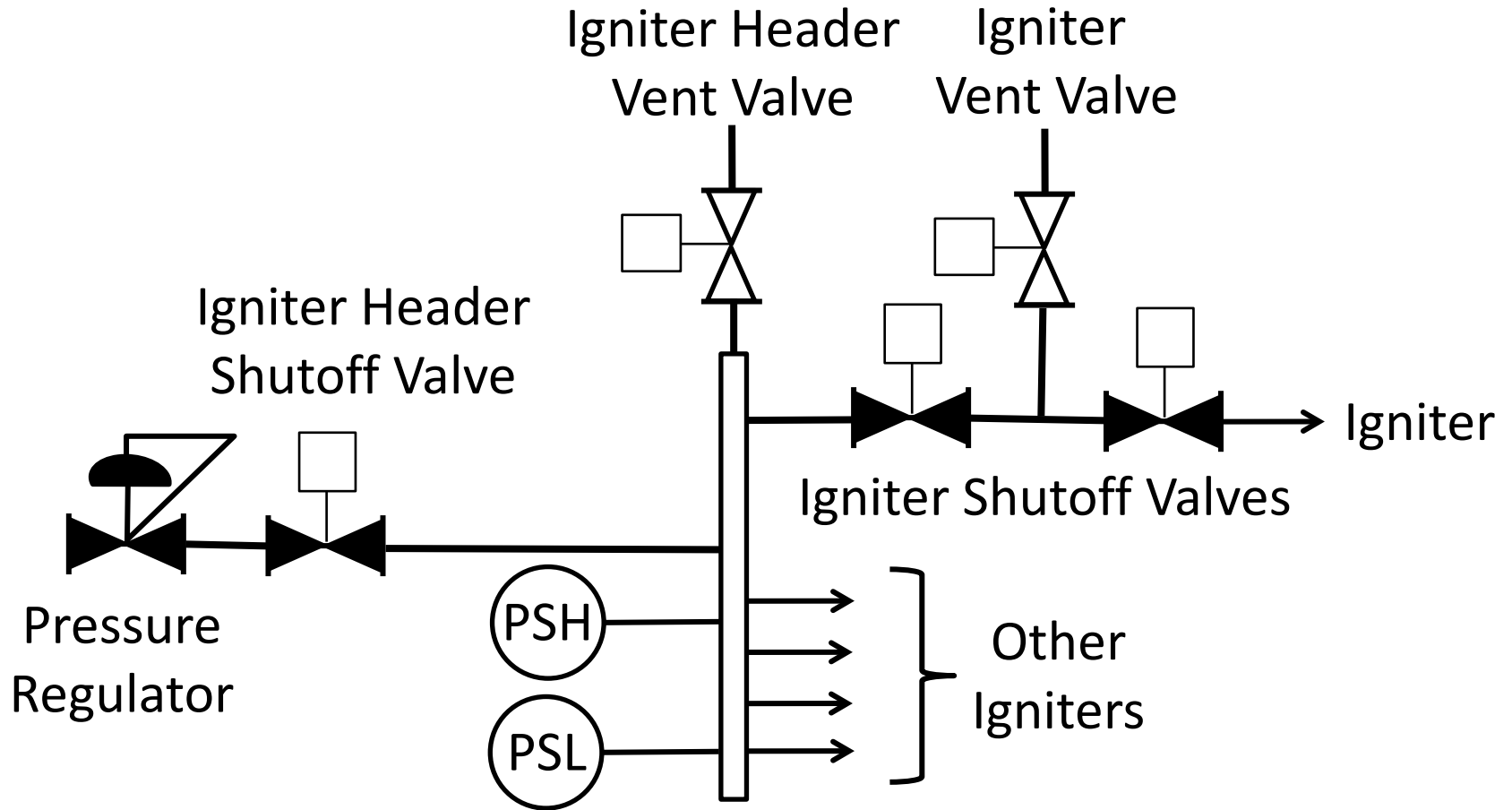

Burner Gas Header

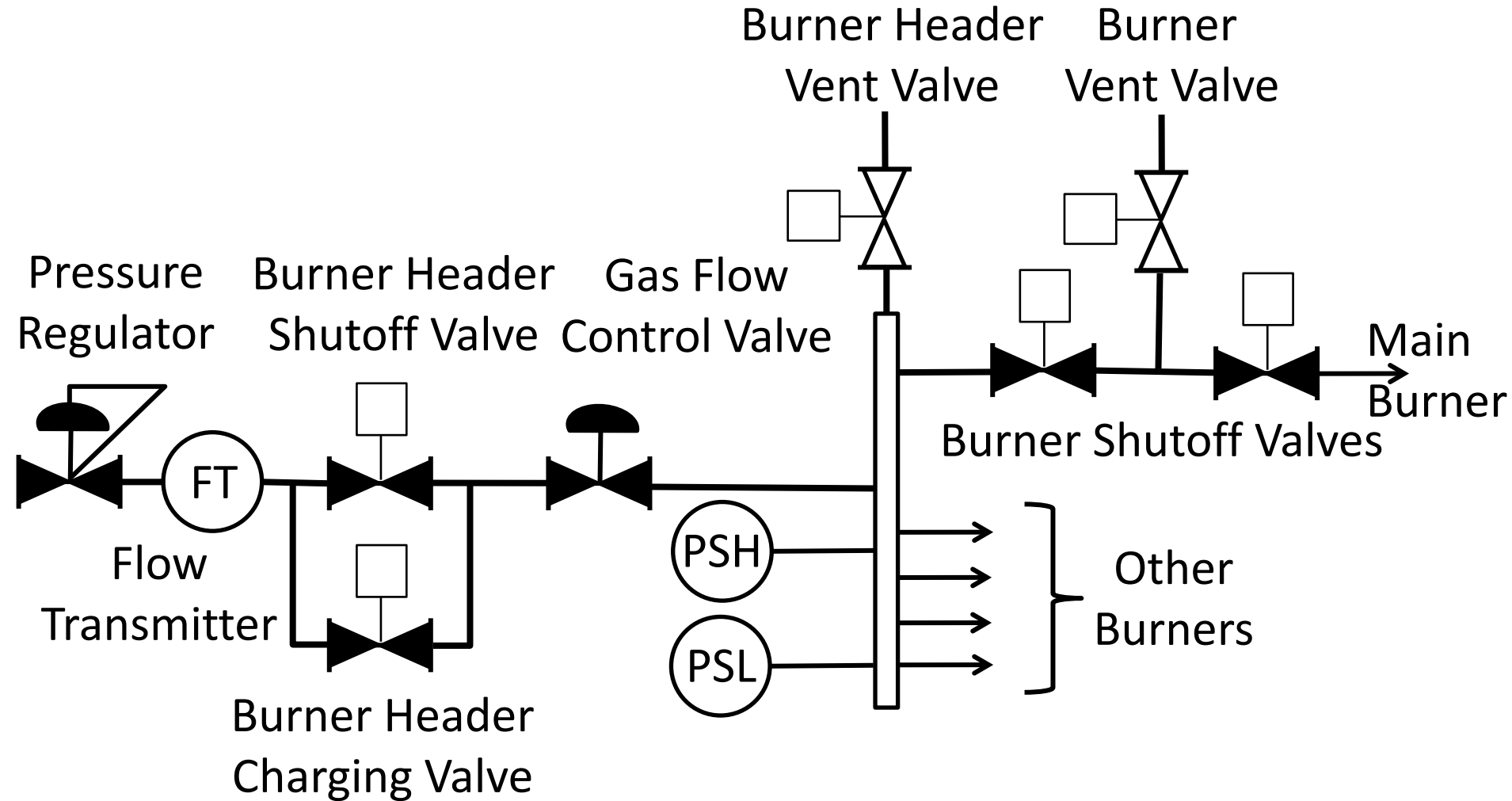

Leak Testing

- Chapter 6 of NFPA 85 describes the requirements for leak testing the gas supply system within the boiler house.
- These requirements include permanent provisions within the gas piping system for performing leak tests.
- Newer Burner Management systems include a leak test function within the start-up routines.

Venting

Per NFPA 85

Vented to Safe
location above
Boiler

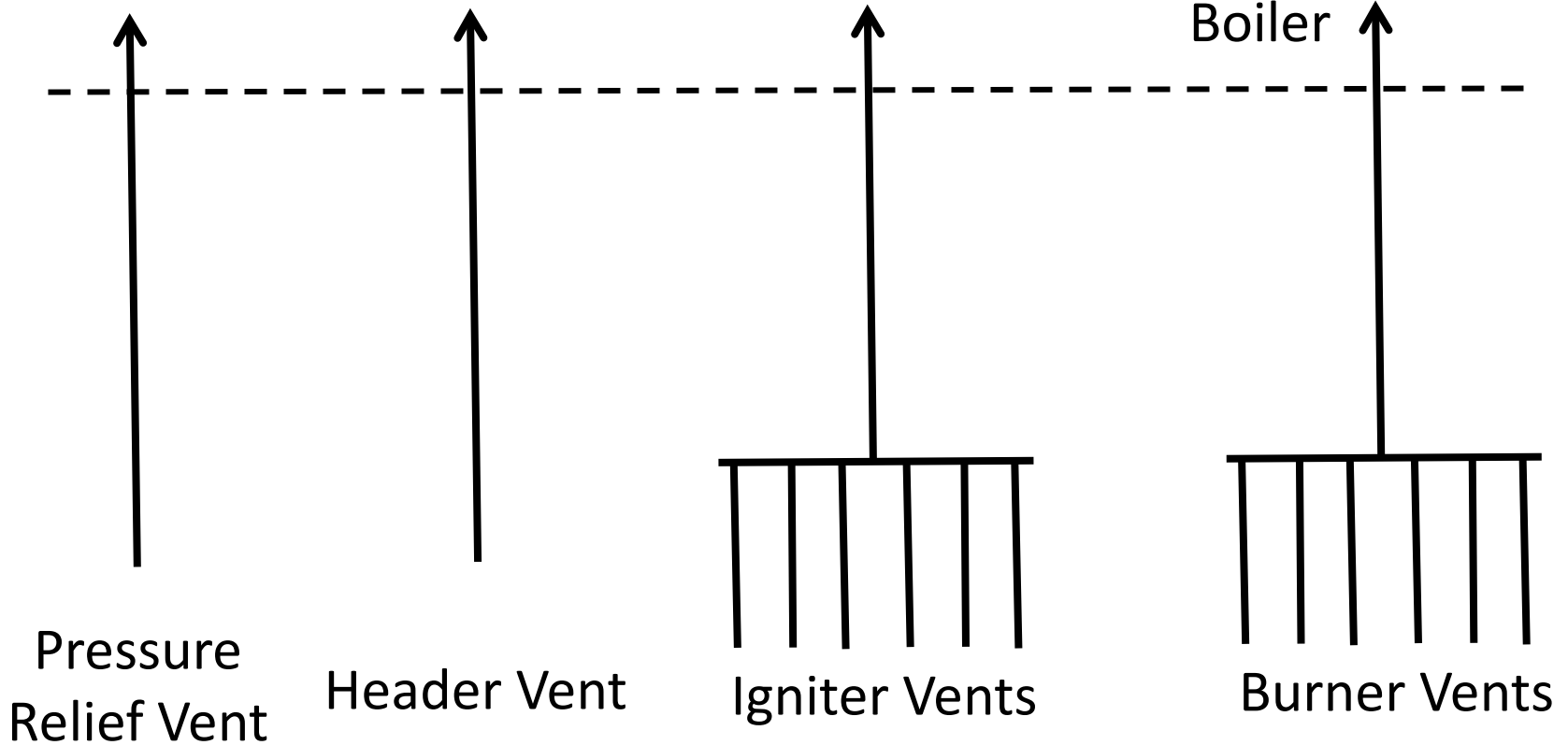

BMS Requirements

- ▶ No single component failure shall prevent a mandatory Master Fuel Trip (MFT)
- ▶ BMS logic system independent from any other logic system
- ▶ Logic protected from unauthorized changes
- ▶ Logic not to be changed on-line
- ▶ Proper operator intervention not to be prevented
- ▶ Trips require operator intervention to reset
- ▶ Signals from boiler control system permitted, but they must be hardwired if part of MFT

Master Fuel Trip (MFT)

Stop All fuel flow to furnace.

- ▶ Close all burner header safety shutoff valves
- ▶ Close igniter header safety shutoff valves
- ▶ Close individual igniter safety shutoff valves
- ▶ De-energize igniter sparks
- ▶ De-energize precipitators and other ignition sources

Flame Scanning - Gas

- Scanner types – Ultraviolet and Ionization
- Sighting to insure flame discrimination
- Gas Recirculation considerations

Flame Scanners – Gas Applications

Ultraviolet (UV) Scanner Head



Ionization Detector



Gas Conversion Architecture

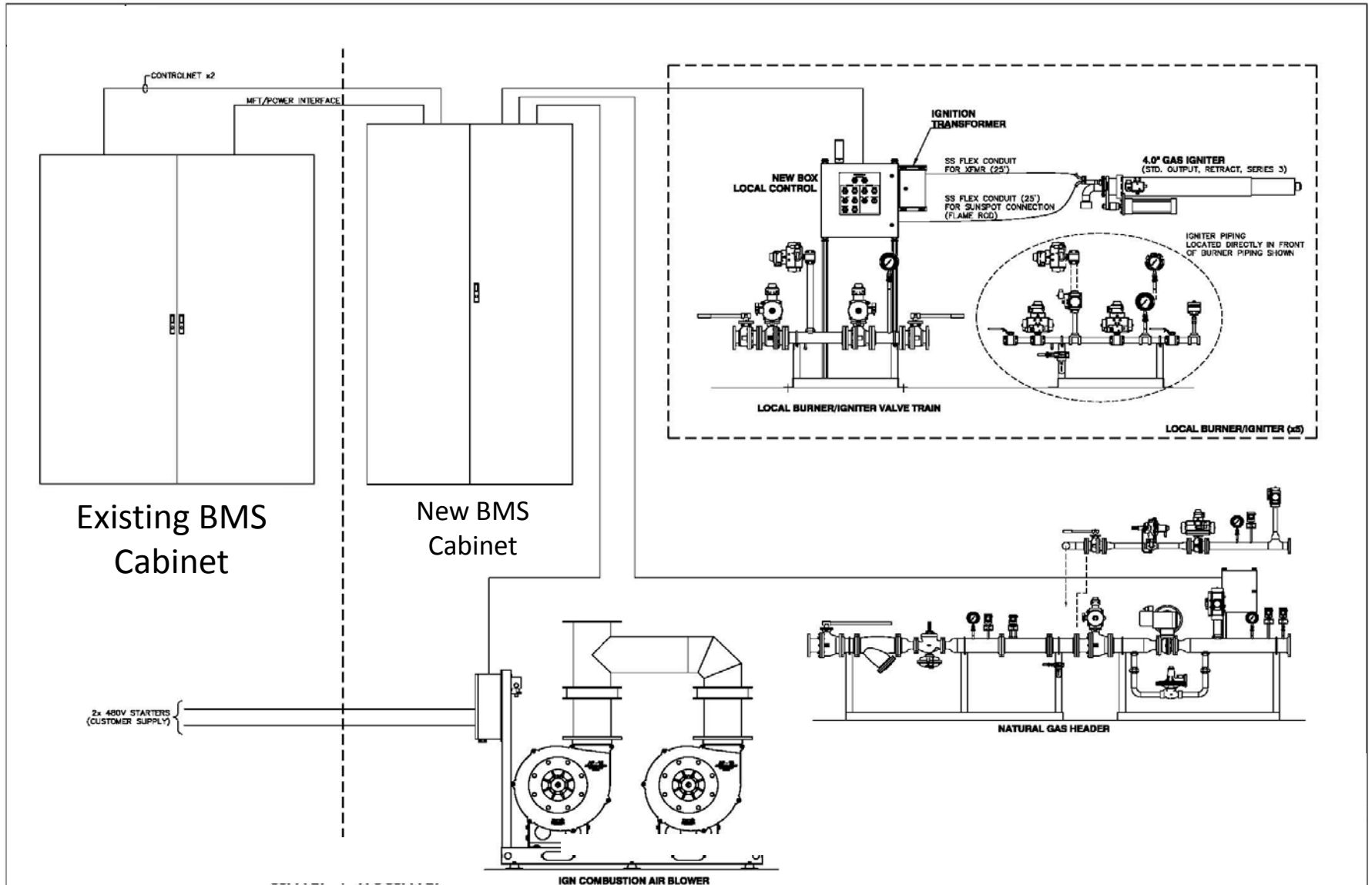

Burner Management System Graphics

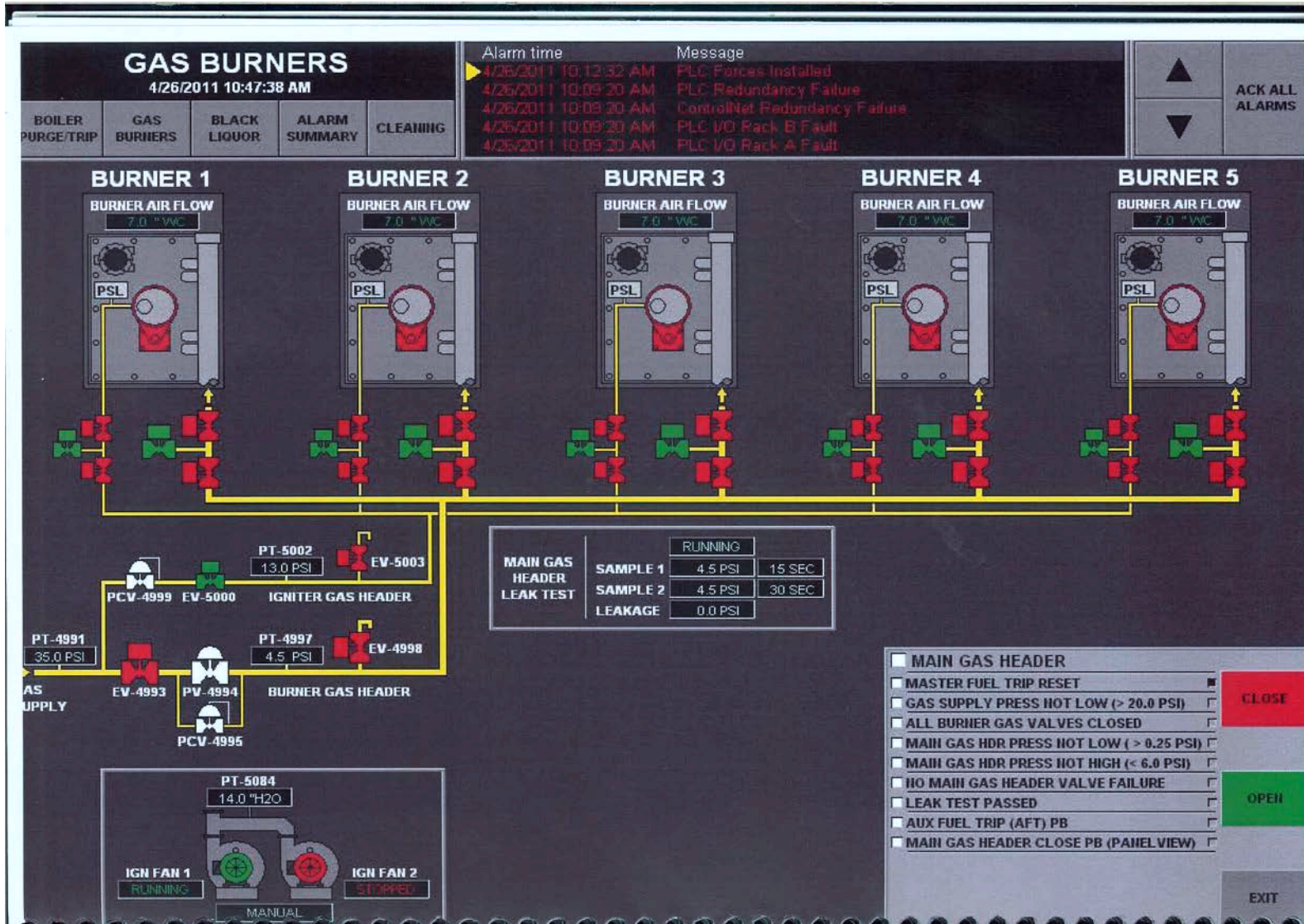

Typical Main Gas Valve Rack Assembly



Combustion Control

1. Existing control strategy is usually sufficient
2. Increase number of burners in service as load increases
3. When co-firing with coal burners, gas is fired through burners that are not firing coal. Separation of fuels via pulverizer groups
4. Maintain burner pressure within specified range

Combustion Control

5. Measure Natural Gas Flow
6. Air flow should always lead fuel flow
7. Fuel to Air curves should be based on BTU values for Gas.
8. Cross limiting of fuel to air
9. Boiler outlet Oxygen used for air trim control

Area Classifications

- A gas conversion can be cause to review the Area Classification.
- NFPA 85 section 4.1.5 and A4.1.5 (Annex) references Hazardous Area Classifications.
- Addition of a Gas Supply to the boiler house does not automatically change the Area Classification to Hazardous.

Take Away Points

1. Main Gas Supply Pressure control and protection
2. Safety shut off valves to insure adequate isolation
3. Venting to a safe location
4. Maintain safe Air/fuel ratios

Questions ?

